

# ATLAS Scissors Assembly

## Current State Map

Wks	Days	Shifts	Hrs	Mins
5	2	7.5	60	60
Days	Shifts	Hrs	Mins	Secs

T30

ATLAS Scissors Assembly		
Clemence, OH		
Raw Materials	62.50	Hrs
Work In Progress	86.25	Hrs
Finished Goods	4.17	Hrs
Defects	500.00	ppm
Takt/50 pairs	150.00	Secs
No Of Shifts	2.00	Per Day
No of WorkDays	5.00	Per Wk
Production Hrs	7.50	Per Shift

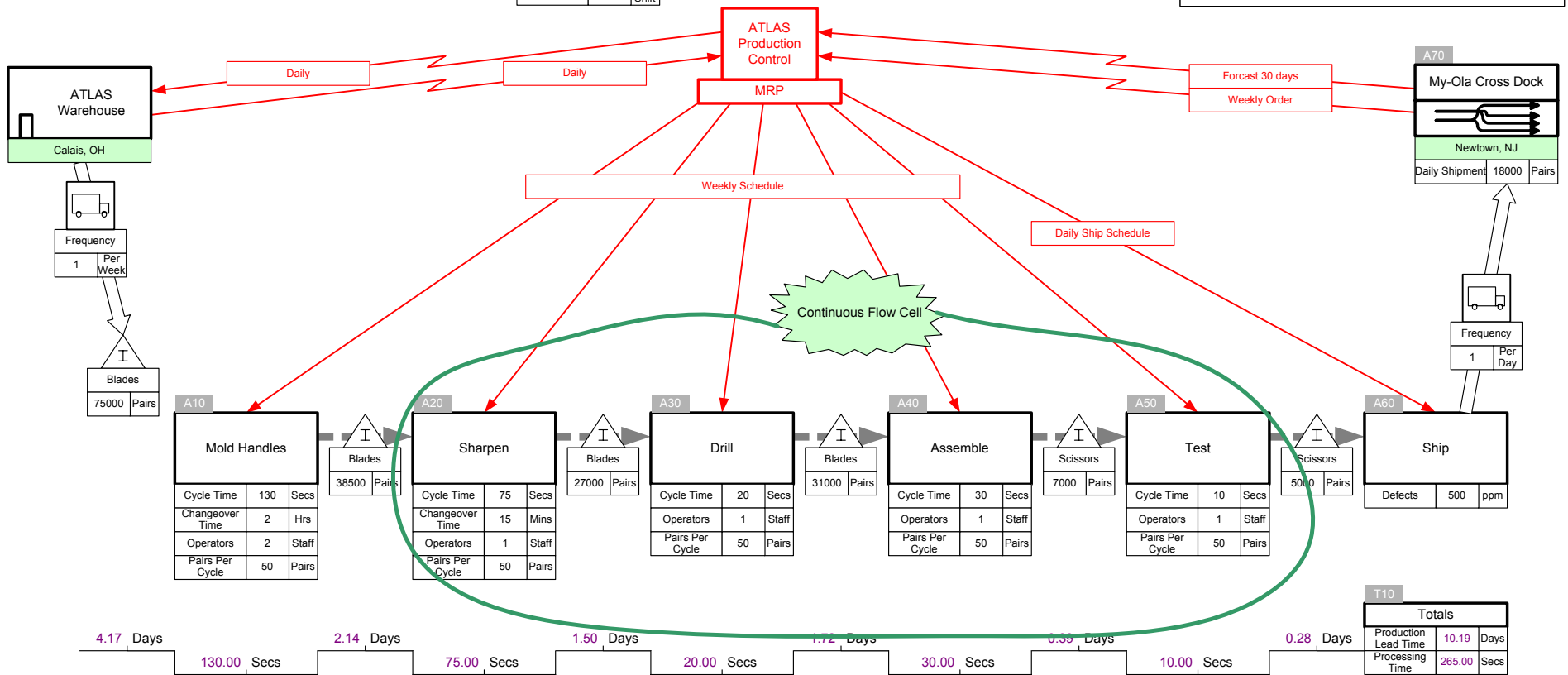
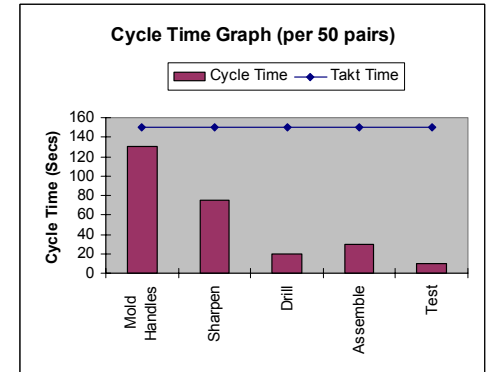

# ATLAS Scissors Assembly

## Future State 1

Wks	Days	Shifts	Hrs	Mins
5	2	7.5	60	60
Days	Shifts	Hrs	Mins	Secs

T30

ATLAS Scissors Assembly		
Clemence, OH		
Raw Materials	15.00	Hrs
Work In Progress	4.17	Hrs
Finished Goods	4.17	Hrs
Defects	500.00	ppm
Takt/50 pairs	150.00	Secs
No Of Shifts	2.00	Per Day
No of WorkDays	5.00	Per Wk
Production Hrs	7.50	Per Shift

### Current State

### Future State 1

Raw Materials	62.50	Hrs
Work In Progress	86.25	Hrs
Finished Goods	4.17	Hrs
Defects	500.00	ppm
Takt/50 pairs	150.00	Secs
No Of Shifts	2.00	Per Day
No of WorkDays	5.00	Per Wk
Production Hrs	7.50	Per Shift

Raw Materials	15.00	Hrs
Work In Progress	4.17	Hrs
Finished Goods	4.17	Hrs
Defects	500.00	ppm
Takt/50 pairs	150.00	Secs
No Of Shifts	2.00	Per Day
No of WorkDays	5.00	Per Wk
Production Hrs	7.50	Per Shift

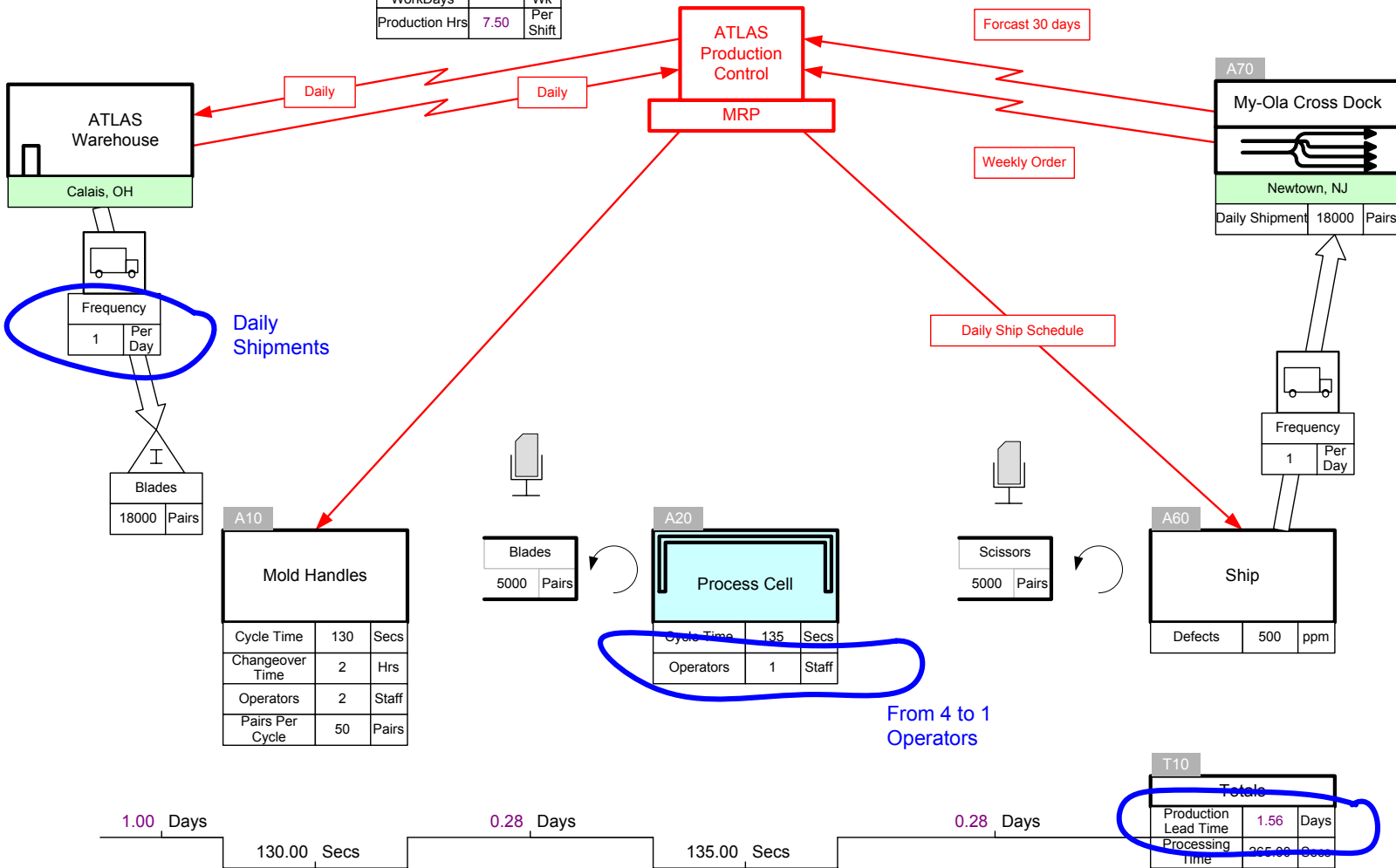

# ATLAS Assembly Cell

## Test Layout & Future State

T10		
Process Cell		
Cycle Time	135.00	Secs
Operator	1	staff

Cycle Time	20	Secs
------------	----	------

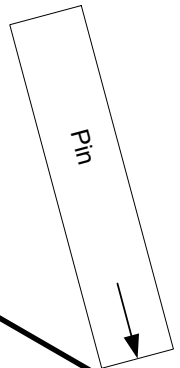
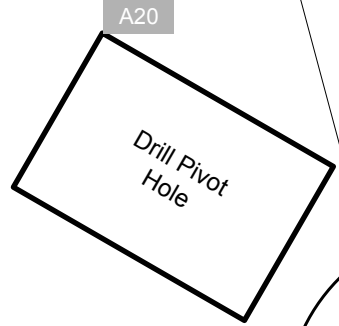

Cycle Time	30	Secs
------------	----	------

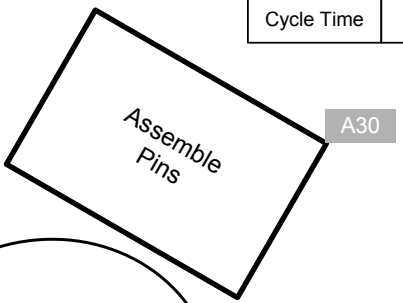

Cycle Time	75	Secs
------------	----	------

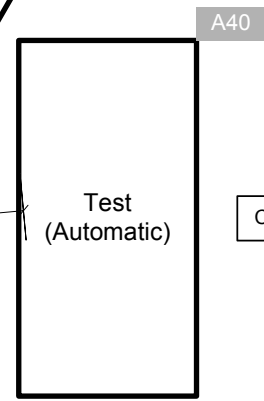
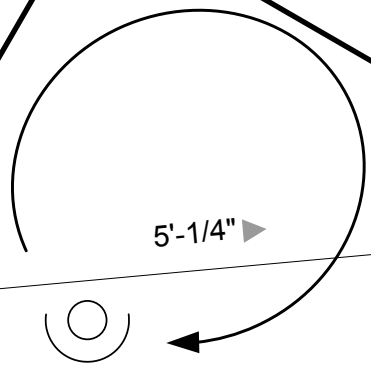
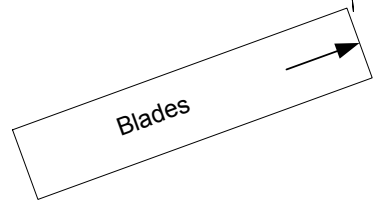
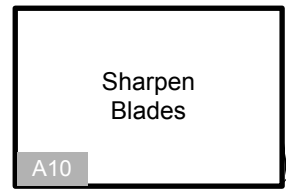

Cycle Time	10	Secs
------------	----	------

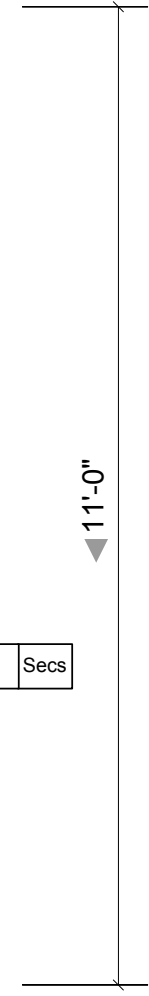
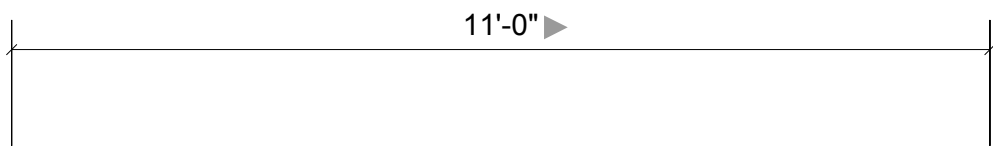

# Scissors - AST / ATLAS / MY-OLA

## Current State Map

Per Week	Per Day
52	5
Per Year	Per Week

